

JELD-WEN, inc.

CUSTOM WOOD FIXED CASEMENT WINDOW (WZ3) (IMPACT)



JELD-WEN, inc.
3737 LAKEPORT BOULEVARD
KLAMATH FALLS, OR 97601
PH: (541) 882-3451 FX: (541) 850-2609

INSTALLATION NOTES:

- ONE (1) INSTALLATION ANCHOR IS REQUIRED AT EACH ANCHOR LOCATION SHOWN.
- THE NUMBER OF INSTALLATION ANCHORS DEPICTED IS THE MINIMUM NUMBER OF ANCHORS TO BE USED FOR PRODUCT INSTALLATION OF THE MAXIMUM SIZE LISTED.
- INSTALL INDIVIDUAL INSTALLATION ANCHORS WITHIN A TOLERANCE OF $\pm 1/2$ INCH (I.E., WITHOUT CONSIDERATION OF TOLERANCES). TOLERANCES ARE NOT CUMULATIVE FROM ONE INSTALLATION ANCHOR TO THE NEXT.
- SHIM AS REQUIRED AT EACH ANCHOR LOCATION WHERE SPACE BETWEEN PRODUCT AND STRUCTURE IS 1/16 INCH OR GREATER. MAXIMUM ALLOWABLE SHIM STACK IS NOT TO EXCEED 1/4". ALL SHIMS ARE TO BE LOAD BEARING, HIGH DENSITY PLASTIC OR BETTER.
- THROUGH FRAME:** FOR INSTALLATION INTO 2X WOOD FRAMING USE #10 WOOD SCREWS OF SUFFICIENT LENGTH TO ACHIEVE 1 1/2 INCH MINIMUM EMBEDMENT INTO WOOD SUBSTRATE.
- THROUGH FRAME:** FOR INSTALLATION THROUGH 1X BUCK TO CONCRETE/MASONRY, OR DIRECTLY INTO CONCRETE/MASONRY, USE 3/16 INCH DIAMETER ITW TAPCONS OF SUFFICIENT LENGTH TO ACHIEVE 1 1/4 INCH MINIMUM EMBEDMENT.
- STRAP INSTALLATION:** FOR INSTALLATION INTO 2X WOOD FRAMING USE TWO (2) #8 WOOD SCREWS PER STRAP OF SUFFICIENT LENGTH TO ACHIEVE 1 1/2 INCH MINIMUM EMBEDMENT INTO WOOD SUBSTRATE.
- MINIMUM EMBEDMENT AND EDGE DISTANCE EXCLUDE WALL FINISHES, INCLUDING BUT NOT LIMITED TO STUCCO, FOAM, BRICK VENEER, AND SIDING.
- INSTALLATION ANCHORS AND ASSOCIATED HARDWARE MUST BE MADE OF CORROSION RESISTANT MATERIAL OR HAVE A CORROSION RESISTANT COATING.
- FOR HOLLOW BLOCK AND GROUT FILLED BLOCK, DO NOT INSTALL INSTALLATION ANCHORS INTO MORTAR JOINTS. EDGE DISTANCE IS MEASURED FROM FREE EDGE OF BLOCK OR EDGE OF MORTAR JOINT INTO FACE SHELL OF BLOCK.
- INSTALLATION ANCHORS SHALL BE INSTALLED IN ACCORDANCE WITH ANCHOR MANUFACTURER'S INSTALLATION INSTRUCTIONS, AND ANCHORS SHALL NOT BE USED IN SUBSTRATES WITH STRENGTHS LESS THAN THE MINIMUM STRENGTH SPECIFIED BY THE ANCHOR MANUFACTURER.
- INSTALLATION ANCHOR CAPACITIES FOR PRODUCTS HEREIN ARE BASED ON SUBSTRATE MATERIALS WITH THE FOLLOWING PROPERTIES:
 - WOOD - MINIMUM SPECIFIC GRAVITY OF 0.55.
 - CONCRETE - MINIMUM COMPRESSIVE STRENGTH OF 3000 PSI.
 - GROUT-FILLED CMU- UNIT STRENGTH CONFORMS TO ASTM C-90 WITH MINIMUM COMPRESSIVE STRENGTH OF 2000 PSI AND GROUT CONFORMS TO ASTM C 476, MINIMUM GROUT COMPRESSIVE STRENGTH OF 2000 PSI.
 - HOLLOW BLOCK CMU - UNIT STRENGTH CONFORMS TO ASTM C-90 WITH MINIMUM COMPRESSIVE STRENGTH OF 2000 PSI.

GENERAL NOTES:

- THE PRODUCT SHOWN HEREIN IS DESIGNED AND MANUFACTURED TO COMPLY WITH THE CURRENT INTERNATIONAL BUILDING CODE (IBC), INTERNATIONAL RESIDENTIAL CODE (IRC), AND FLORIDA BUILDING CODE (FBC), EXCLUDING HVHZ AND HAS BEEN EVALUATED ACCORDING TO THE FOLLOWING:
 - AAMA/WDMA/CSA 101/I.S.2/A440-08
 - TAS 201-94
 - TAS 202-94
 - TAS 203-94
 - ASTM E1886-13
 - ASTM E1996-14
- ADEQUACY OF THE EXISTING STRUCTURAL CONCRETE/MASONRY AND 2X FRAMING AS A MAIN WIND FORCE RESISTING SYSTEM CAPABLE OF WITHSTANDING AND TRANSFERRING APPLIED PRODUCT LOADS TO THE FOUNDATION IS THE RESPONSIBILITY OF THE ENGINEER OR ARCHITECT OF RECORD FOR THE PROJECT OF INSTALLATION.
- 1X AND 2X BUCKS (WHEN USED) SHALL BE DESIGNED AND ANCHORED TO PROPERLY TRANSFER ALL LOADS TO THE STRUCTURE. BUCK DESIGN AND INSTALLATION IS THE RESPONSIBILITY OF THE ENGINEER OR ARCHITECT OF RECORD FOR THE PROJECT OF INSTALLATION.
- THE INSTALLATION DETAILS DESCRIBED HEREIN ARE GENERIC AND MAY NOT REFLECT ACTUAL CONDITIONS FOR A SPECIFIC SITE. IF SITE CONDITIONS CAUSE INSTALLATION TO DEVIATE FROM THE REQUIREMENTS DETAILED HEREIN, A LICENSED ENGINEER OR ARCHITECT SHALL PREPARE SITE SPECIFIC DOCUMENTS FOR USE WITH THIS DOCUMENT.
- APPROVED IMPACT PROTECTIVE SYSTEM **IS NOT REQUIRED** ON THIS PRODUCT IN AREAS REQUIRING IMPACT RESISTANCE IN WIND ZONES 3 OR LESS.
- APPROVED IMPACT PROTECTIVE SYSTEM **IS REQUIRED** ON THIS PRODUCT IN AREAS REQUIRING IMPACT RESISTANCE IN WIND ZONE 4.
- WINDOW FRAME MATERIAL: PONDEROSA PINE (*MIN S.G. = 0.40*)
- GLASS MEETS THE REQUIREMENTS OF ASTM E 1300 GLASS CHARTS. SEE SHEET 4 FOR GLAZING DETAILS.
- FOR APPROVED MULLION, LIMITS OF USE & CONFIGURATIONS, SEE FL15861.

TABLE OF CONTENTS	
SHEET	SHEET DESCRIPTION
1	INSTALLATION & GENERAL NOTES
2	ELEVATION & ANCHOR LAYOUTS
3	VERTICAL & HORIZONTAL SECTIONS
4	GLAZING DETAILS

OVERALL SIZE		DESIGN PRESSURE	MISSILE IMPACT RATING
WIDTH	HEIGHT		
72"	84"	+50/-50 PSF	SMALL & LARGE MISSILE IMPACT

TITLE: CUSTOM WOOD
FIXED CASEMENT WINDOW
(WZ3) (IMPACT)
INSTALLATION
& GENERAL NOTES

PREPARED BY:
BUILDING DROPS, INC.
398 E. DANIA BEACH BLVD., STE. 338
DANIA BEACH, FL 33004
PH: (954)399-8478
FAX: (954)744-4738
WEB: www.buildingdrops.com



REMARKS	BY	DATE
7TH FBC CODE CHANGE	SR	4.03.20
8TH FBC CODE CHANGE	MG	2.06.23

THE INSTALLATION DETAILS DESCRIBED HEREIN ARE GENERIC AND MAY NOT REFLECT ACTUAL CONDITIONS FOR A SPECIFIC SITE. IF SITE CONDITIONS CAUSE INSTALLATION TO DEVIATE FROM THE REQUIREMENTS DETAILED HEREIN, A LICENSED ENGINEER OR ARCHITECT SHALL PREPARE SITE SPECIFIC DOCUMENTS FOR USE WITH THIS DOCUMENT.



HERMES F. NORERO, P.E.
FLORIDA P.E. No. 73778
BUILDING DROPS, INC.
398 E. DANIA BEACH BLVD. # 338
DANIA BEACH, FL 33004
FBPE CERT. OF AUTHORIZATION No. 29578

DATE:	01.23.14	
DWG. BY:	TJM	CHK. BY: HFN
SCALE:	NTS	
DWG. #:	JW028	
SHEET	1	

z:\projects\jeld-wen\cc-22-1133.1 - fbc submittal - 2023 code change\116897.1\jw028 fixed casement.dwg
 2/21/2023 4:08 PM

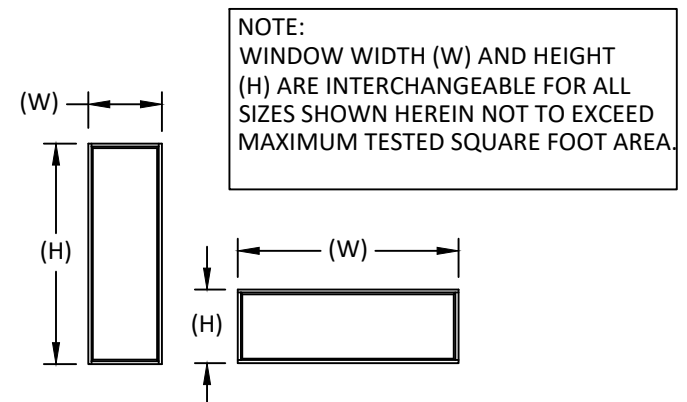
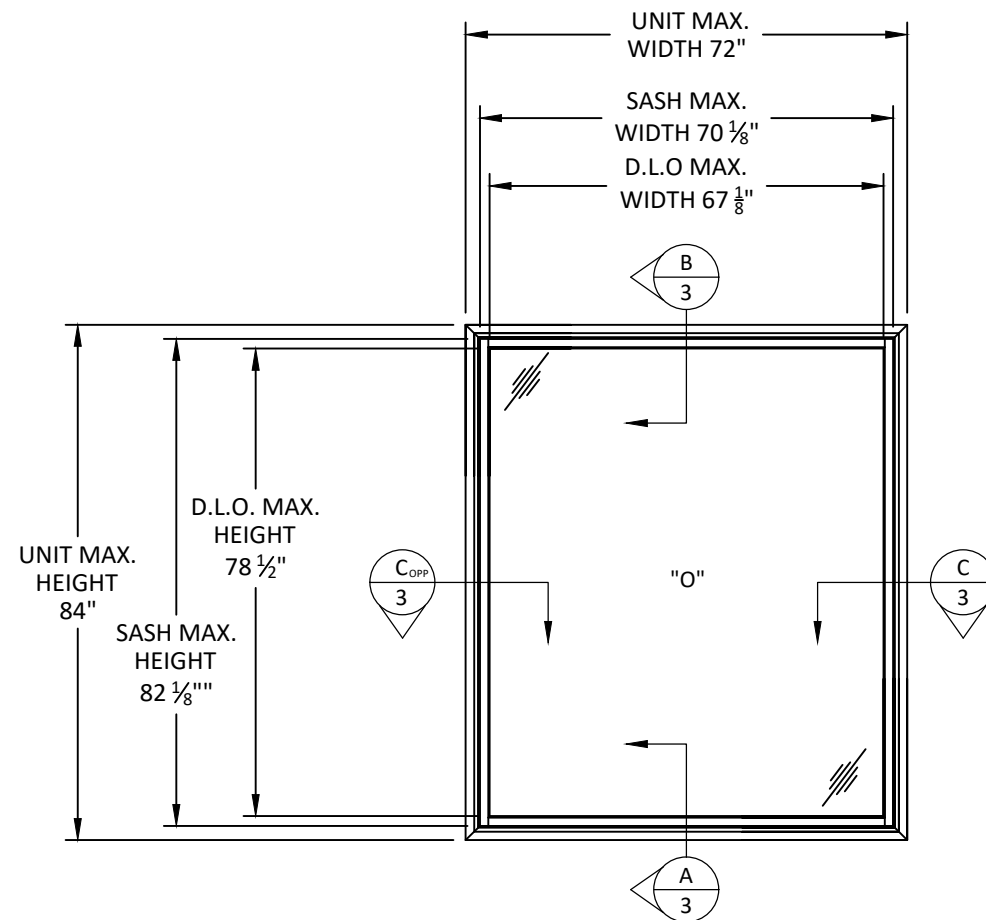

TYPICAL ELEVATION

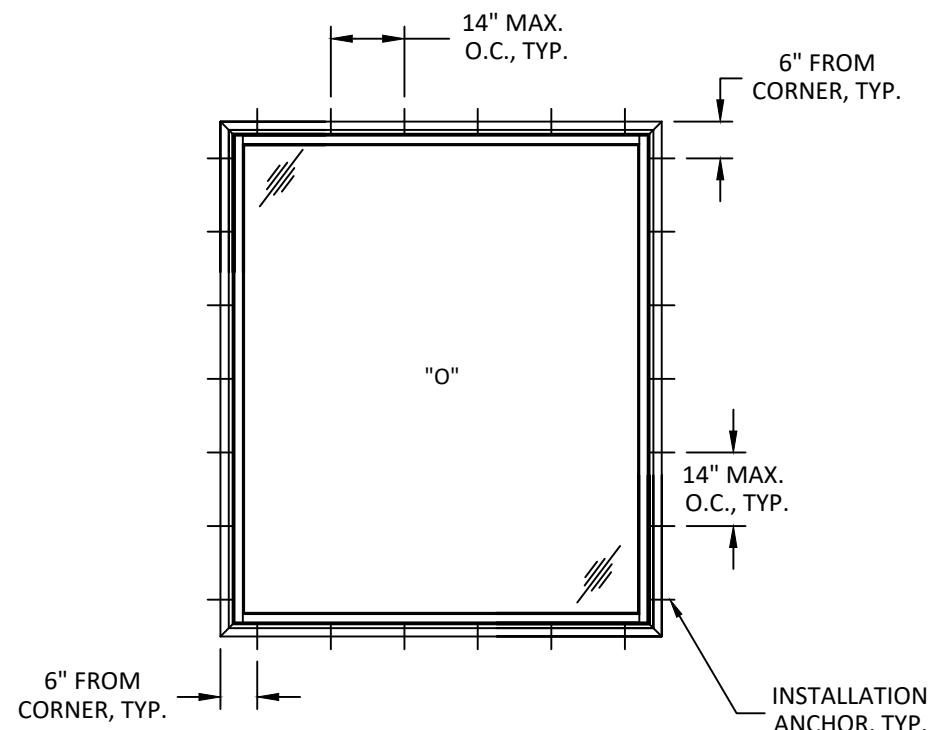

ANCHOR LAYOUT
STRAP INSTALLATION

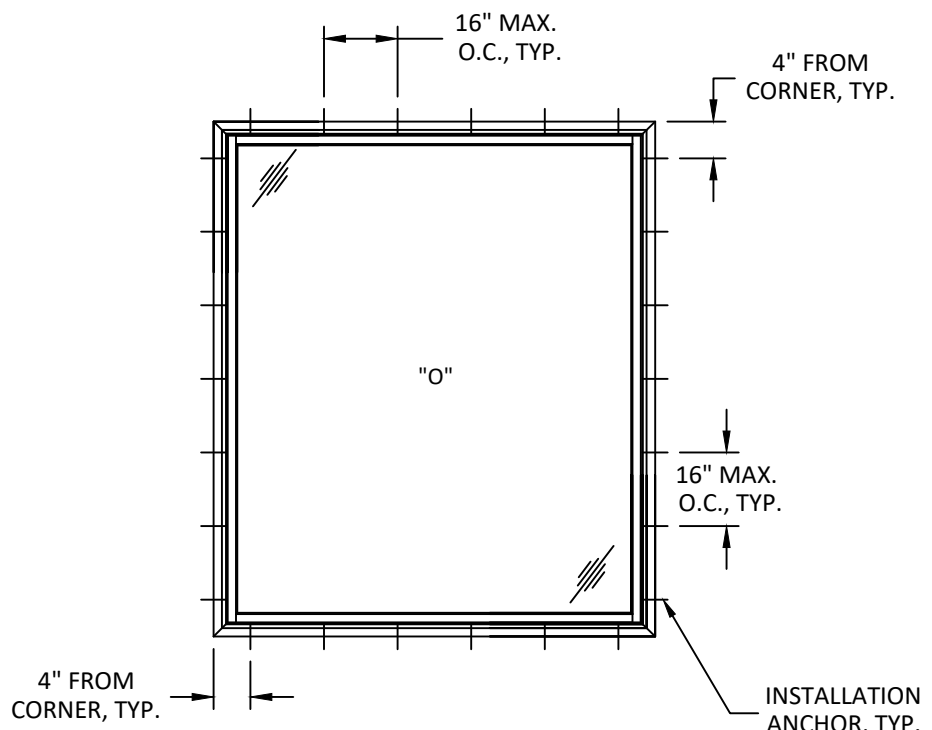

ANCHOR LAYOUT
THROUGH FRAME INSTALLATION

JELD-WEN
 WINDOWS & DOORS
 JELD-WEN, inc.
 3737 LAKEPORT BOULEVARD
 KLAMATH FALLS, OR 97601
 PH: (541) 882-3451 FX: (541) 850-2609

TITLE: **CUSTOM WOOD
 FIXED CASEMENT WINDOW
 (WZ3) (IMPACT)**
 ELEVATION & ANCHOR LAYOUTS

PREPARED BY:
BUILDING DROPS, INC.
 398 E. DANIA BEACH BLVD., STE. 338
 DANIA BEACH, FL 33004
 PH: (954) 399-8478
 FAX: (954) 744-4738
 WEB: www.buildingdrops.com

REMARKS	BY	DATE
7TH FBC CODE CHANGE	SR	4.03.20
8TH FBC CODE CHANGE	MG	2.06.23

THE INSTALLATION DETAILS DESCRIBED HEREIN ARE GENERIC AND MAY NOT REFLECT ACTUAL CONDITIONS FOR A SPECIFIC SITE. IF SITE CONDITIONS CAUSE INSTALLATION TO DEVIATE FROM THE REQUIREMENTS DETAILED HEREIN, A LICENSED ENGINEER OR ARCHITECT SHALL PREPARE SITE SPECIFIC DOCUMENTS FOR USE WITH THIS DOCUMENT.



HERMES F. NORERO, P.E.
 FLORIDA P.E. No. 73778
 BUILDING DROPS, INC.
 398 E. DANIA BEACH BLVD. # 338
 DANIA BEACH, FL 33004
 FBPE CERT. OF AUTHORIZATION No. 29578

DATE:	01.23.14
DWG. BY:	TJM
CHK. BY:	HFN
SCALE:	NTS
DWG. #:	JW028

SHEET
2
 OF 4

z:\projects\jeld-wen\cc-22-1133.1 - fbc submittal - 2023 code change\116897\dwg\116897_1\jw028 fixed casement.dwg
 2/21/2023 4:08 PM

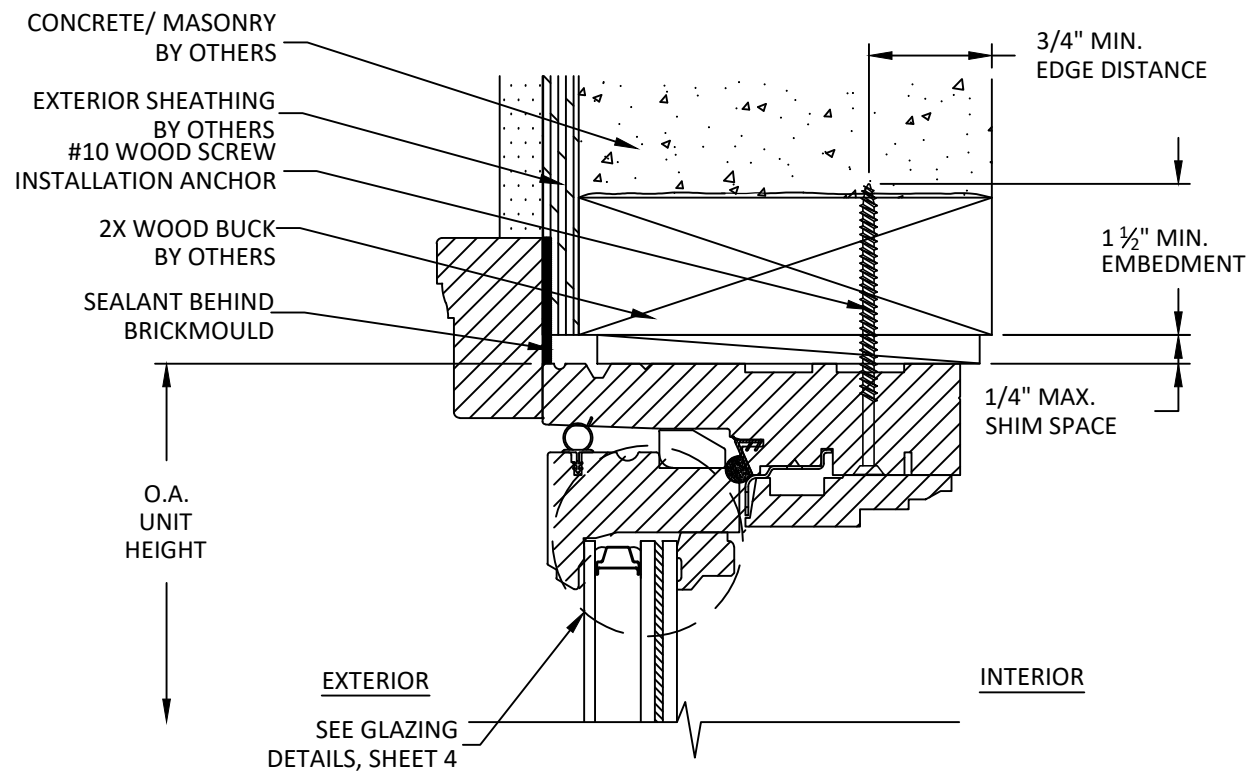

B
3
VERTICAL SECTION
HEAD - 2X WOOD BUCK
THROUGH FRAME INSTALLATION, TYP.

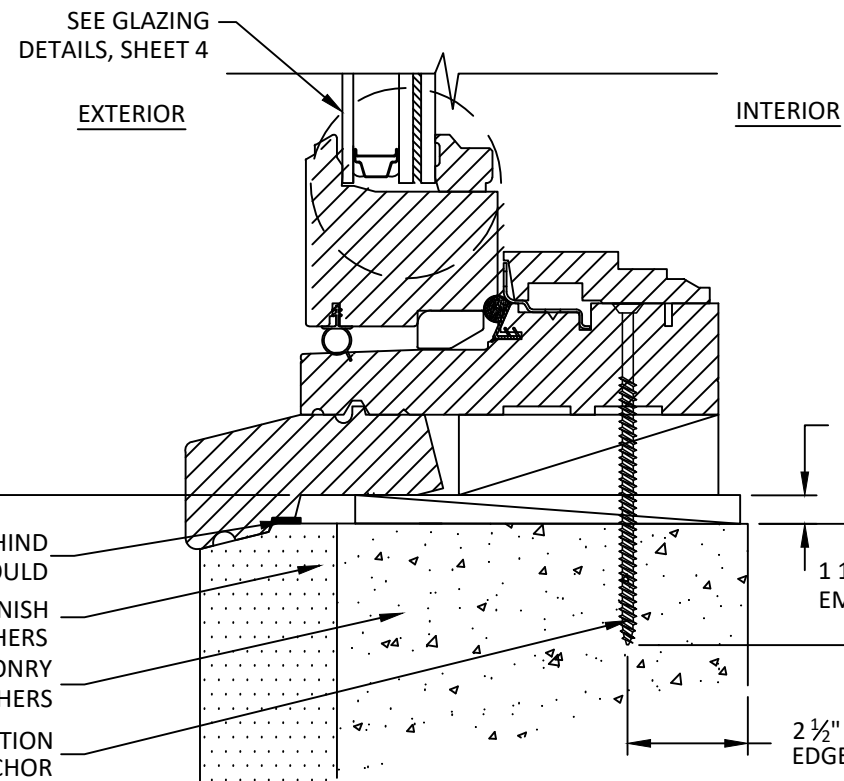

A
3
VERTICAL SECTION
SILL - CONCRETE/MASONRY
THROUGH FRAME INSTALLATION, TYP.

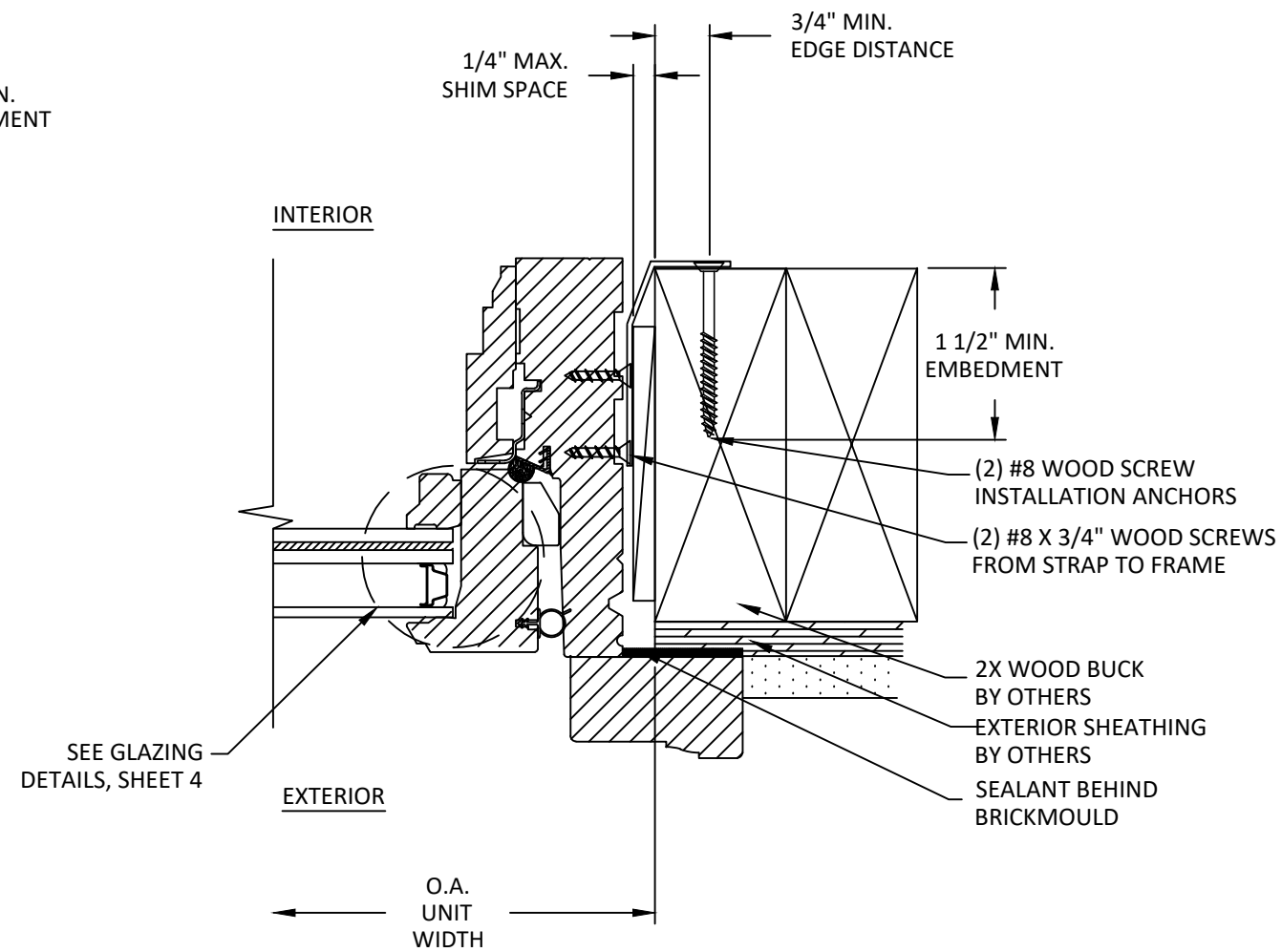

C
3
HORIZONTAL SECTION
JAMB - 2X WOOD BUCK
STRAP INSTALLATION, TYP.

NOTE: 1X WOOD BUCK
BY OTHERS IS OPTIONAL
FOR MASONRY APPLICATIONS

TITLE: CUSTOM WOOD
FIXED CASEMENT WINDOW
(WZ3) (IMPACT)
VERTICAL & HORIZONTAL
SECTIONS

PREPARED BY:
BD
BUILDING DROPS
BUILDING DROPS, INC.
398 E. DANIA BEACH BLVD., STE. 338
DANIA BEACH, FL 33004
PH: (954) 399-8478
FAX: (954) 744-4738
WEB: www.buildingdrops.com

REMARKS	BY	DATE
7TH FBC CODE CHANGE	SR	4.03.20
8TH FBC CODE CHANGE	MG	2.06.23

THE INSTALLATION DETAILS DESCRIBED HEREIN ARE GENERIC AND MAY NOT REFLECT ACTUAL CONDITIONS FOR A SPECIFIC SITE. IF SITE CONDITIONS CAUSE INSTALLATION TO DEVIATE FROM THE REQUIREMENTS DETAILED HEREIN, A LICENSED ENGINEER OR ARCHITECT SHALL PREPARE SITE SPECIFIC DOCUMENTS FOR USE WITH THIS DOCUMENT.

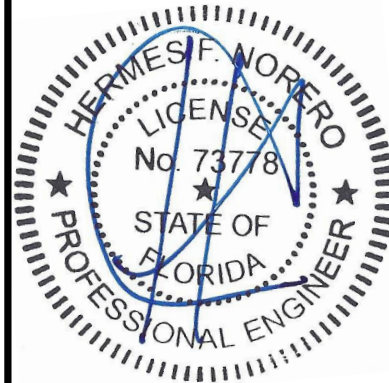

HERMES F. NORERO, P.E.
FLORIDA P.E. No. 73778
BUILDING DROPS, INC.
398 E. DANIA BEACH BLVD. # 338
DANIA BEACH, FL 33004
FBPE CERT. OF AUTHORIZATION No. 29578

DATE:	01.23.14	
DWG. BY:	TJM	CHK. BY: HFN
SCALE:	NTS	
DWG. #:	JW028	

SHEET
3
OF 4

z:\projects\jeld-wen\2023 code change\116897\dwg\116897.1\jw028 fixed casement.dwg

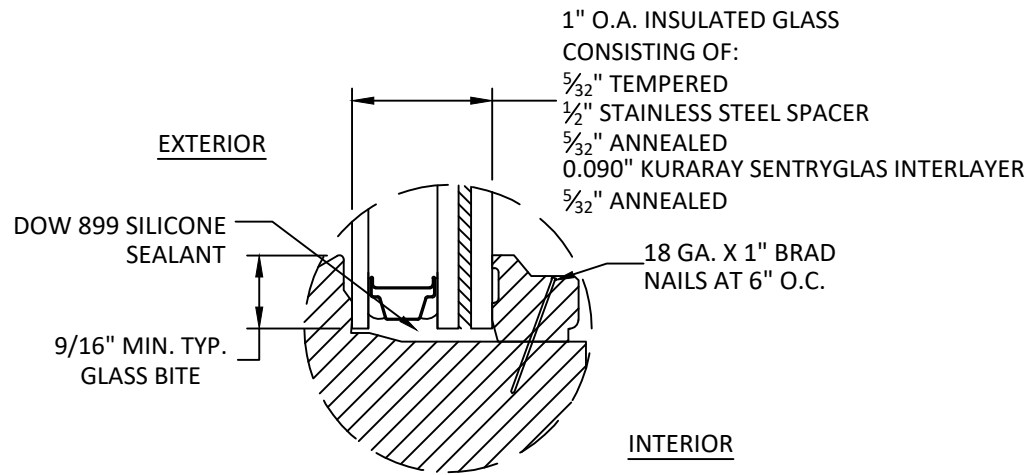

GLAZING DETAIL 1

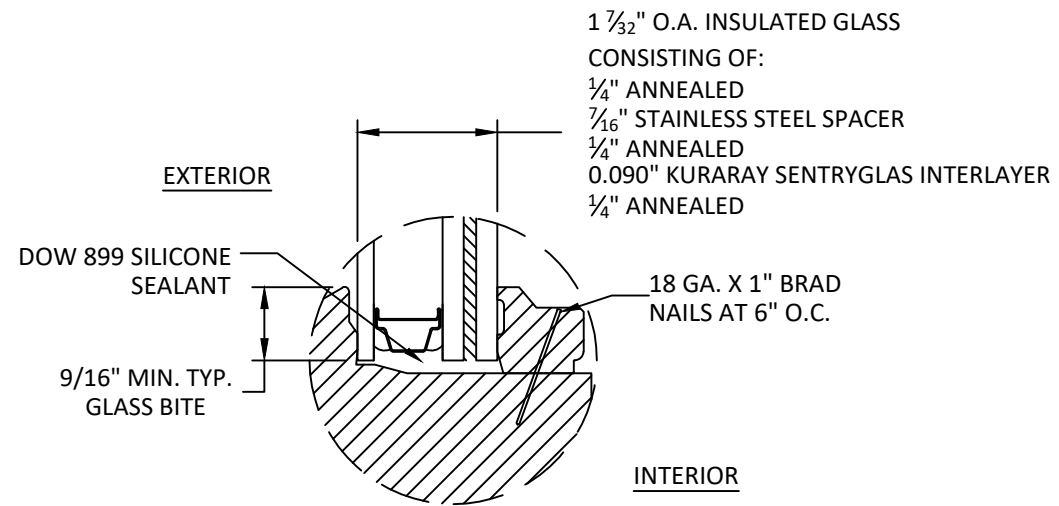

GLAZING DETAIL 2

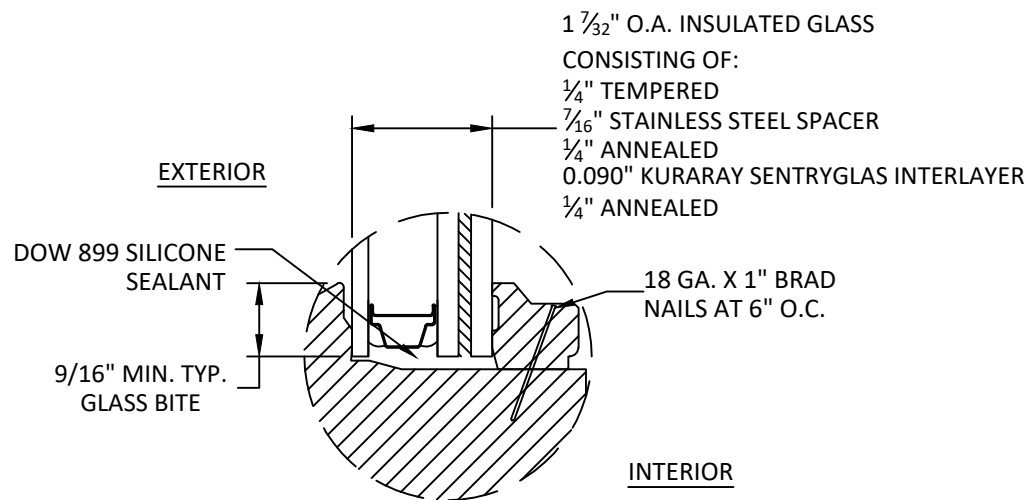

GLAZING DETAIL 3

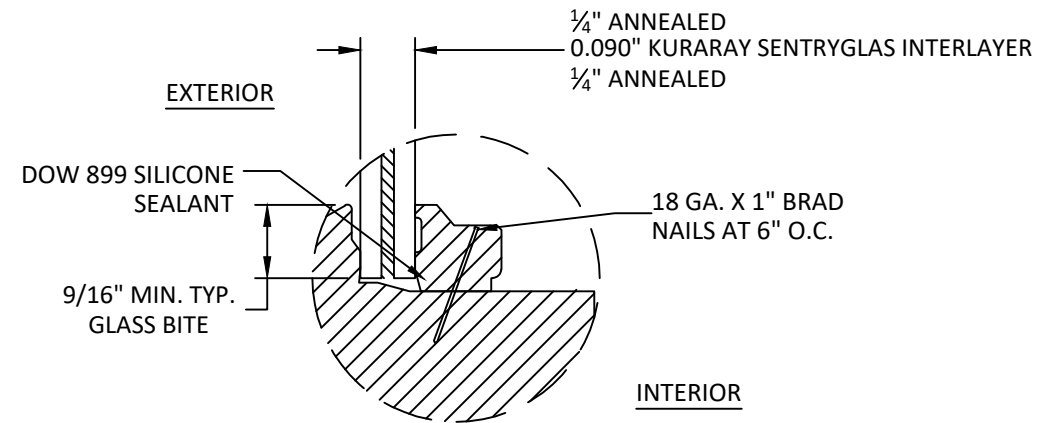

GLAZING DETAIL 4

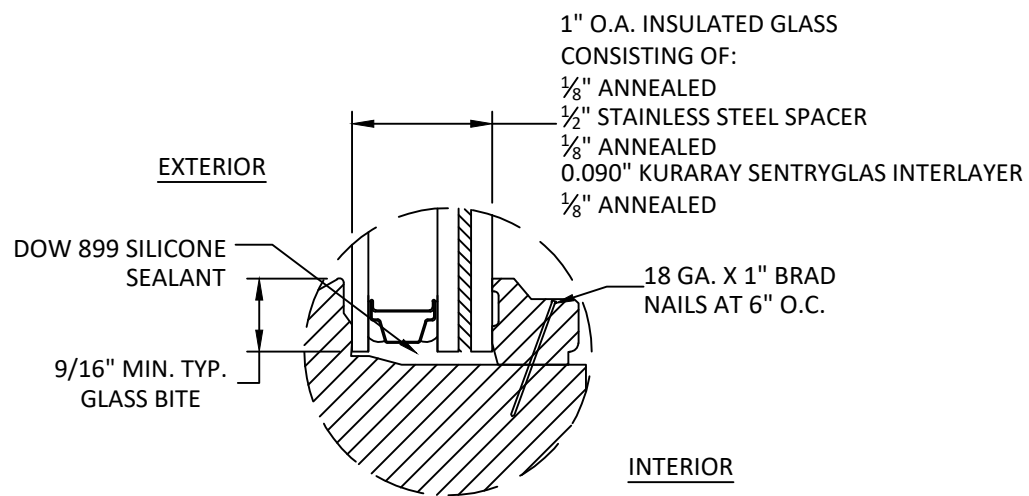

GLAZING DETAIL 5

- NOTE:**
1. ALL GLAZING COMPLIES WITH ASTM E1300 REQUIREMENTS AS PER CH 24 OF THE FBC. TEMPER AND SAFETY GLAZING REQUIREMENTS SHALL BE REVIEWED ON A SITE SPECIFIC BASIS.
 2. SETTING BLOCK DUROMETER HARDNESS OF 70-90 (SHORE A) AS REFERENCED IN CHAPTER 24.
 3. SETTING BLOCKS TO BE LOCATED AT 1/4 SPAN LENGTH FOR GLASS WIDER THAN 36" AS PER CHAPTER 24.
 4. D.L.O. MAY NOT EXCEED MAX DIMENSIONS SHOWN IN ELEVATIONS.



JELD-WEN, inc.
3737 LAKEPORT BOULEVARD
KLAMATH FALLS, OR 97601
PH: (541) 882-3451 FX: (541) 850-2609

TITLE: CUSTOM WOOD
FIXED CASEMENT WINDOW
(WZ3) (IMPACT)
GLAZING DETAILS

PREPARED BY:
BUILDING DROPS, INC.
398 E. DANIA BEACH BLVD., STE. 338
DANIA BEACH, FL 33004
PH: (954) 399-8478
FAX: (954) 744-4738
WEB: www.buildingdrops.com



REMARKS	BY	DATE
7TH FBC CODE CHANGE	SR	4.03.20
8TH FBC CODE CHANGE	MG	2.06.23

THE INSTALLATION DETAILS DESCRIBED HEREIN ARE GENERIC AND MAY NOT REFLECT ACTUAL CONDITIONS FOR A SPECIFIC SITE. IF SITE CONDITIONS CAUSE INSTALLATION TO DEVIATE FROM THE REQUIREMENTS DETAILED HEREIN, A LICENSED ENGINEER OR ARCHITECT SHALL PREPARE SITE SPECIFIC DOCUMENTS FOR USE WITH THIS DOCUMENT.



HERMES F. NORERO, P.E.
FLORIDA P.E. No 73778
BUILDING DROPS, INC
398 E. DANIA BEACH BLVD. # 338
DANIA BEACH, FL 33004
FBPE CERT. OF AUTHORIZATION No. 29578

DATE:	01.23.14	
DWG. BY:	TJM	CHK. BY: HFN
SCALE:	NTS	
DWG. #:	JW028	

SHEET
4
OF 4